

Lynx Power System, Inc.

Model: 20SD

Ratings:

		50Hz	60Hz
Standby:	kw	18	20
	kva	22.5	25
Prime:	kw	16	18
	kva	20	22.5

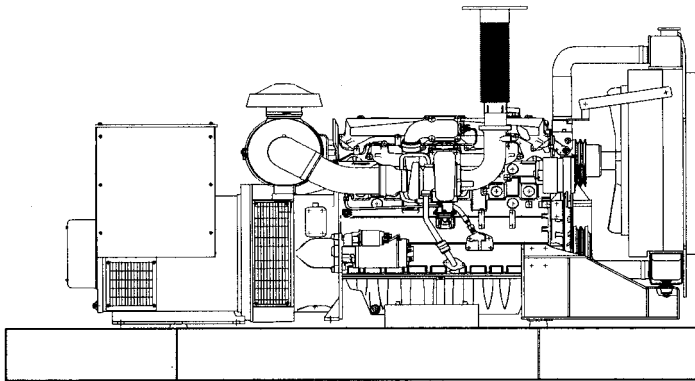

Product Features

- * System reliability and longevity begin with design experience and integrity.
- * Heavy duty 4 cycle industrial engine for reliability and fuel efficiency.
- * Heavy duty steel base with integral vibration isolators.
- * Single source responsibility for the generator set and accessories.
- * Microprocessor based control system providing digital metering and monitoring.
- * Brushless rotating field generator with class H insulation.
- * Unit conforms to CSA, NEMA, EGSA, ANSI and other standards.
- * Prototype and production tested to insure one step load acceptance per NFPA 110.
- * Two year limited warranty on generator sets and accessories.
- * Extended warranty available upon request.

Application & Engineering Data

Engine

Engine Specifications	60Hz	50Hz
Manufacturer	Perkins	
Engine, Model, Type	3.152 4 Cycle	
Cylinder Arrangement	3 in-line	
Displacement, L	2.5	
Bore and Stroke, in. (mm)	3.6 (91.4) x 5 (127)	
Compression ratio	16.5:1	
Piston Speed, ft/sec. (m/sec)	20.8 (6.35)	
Rated RPM	1800	1500
Max. Power at Rated RPM, hp (kw)	37.7 (28.1)	32.5 (24.2)
Cylinder Head Material	Cast Iron	
Crankshaft Material	Forged Steel	
Governor Type Make / Model	Mechanical Stanadyne (DB4)	
Frequency regulation, no load to full load	3-5%	
Frequency regulation, steady state	±0.8%	
Air Cleaner type, all models	Dry Paper Element	
Combustion air, cfm (m ³ /min.)	77 (2.18)	57 (1.61)

Cooling

Cooling System	60Hz	50Hz
Ambient Temperature °F (°C)	115 (46)	
Radiator system capacity, including engine, gal. (L)	3.13 (11.85)	
Engine jacket water flow, gpm (Lpm)	10.8 (41)	9 (34)
Heat rejected to cooling water at rated kw, dry exhaust Btu / min.	960	850
Water pump type	Centrifugal	
Fan diameter, including blades, in (mm)	15 (381)	
Fan hp (kw)	1.1 (.8)	.6 (.4)
Max. restriction of cooling air, intake and discharge side of rad., in. LBF in. ² (kPa)	5.0 (35)	
Radiator - cooled cooling air cfm (m ³ /min.)	3320 (94)	3000 (85)

Lubrication

Lubricating System	60Hz	50Hz
Type	Full Pressure	
Oil pan capacity with filter, qts. (L)	6.5 (6.17)	
Oil filter, quantity, type	1 Spin On	
Oil cooler	none	

Control Panel

Standard Control Panel provides: Digital readout of AC volts, AC amps and frequency; continuous display of engines. Oil pressure, water temperature and battery voltage; display of running time, system diagnostics and service information, safety shutdowns for overcrank, overspeed, low oil pressure and high water temperature; and remote and local start/stop capabilities with speed signal monitoring.

Engine Electrical

Engine Electrical System	60Hz	50Hz
Battery changing alternator:		
Ground (negative/positive).....	Negative	
Volts (DC).....	12	
Ampere rating.....	45	
Starter motor rated voltage (DC)	12	
Recommended battery cold cranking amps (CCA) rating 0°F (-18°C)	535	
Quantity of batteries	1	
Battery voltage (DC)	12	

Fuel

Fuel System	60Hz	50Hz
Fuel supply line, min. ID, in. (mm)	5/16 (7.93)	
Fuel return line, min. ID, in. (mm)	1/4 (6.35)	
Max. lift, engine-driven fuel pump, ft. (m)	6 (1.8)	
Max. fuel flow, gph (Lph)	3.6 (13.7)	3.2 (12.2)
Fuel prime pump	Manual	
Fuel filter	Cartridge	
Recommended fuel	#2 Diesel	

Fuel Consumption

Fuel Consumption	60Hz	50Hz
Diesel, gph (Lph) at % of load		
100%	1.8 (7)	1.56 (6)
75%	1.32 (5.4)	1.2 (4.6)
50%	.96 (4)	.84 (3.3)

Exhaust

Exhaust System	60Hz	50Hz
Exhaust flow at rated kw, cfm (m ³ /min.)	209 (5.91)	152 (4.31)
Exhaust temperature at rated kw, dry exhaust, °F (°C)	1040 (560)	1022 (550)
Maximum allowable back pressure, in. Hg (kPa)	3 (10.2)	
Exhaust outlet size at hookup, in. (mm)	2 (50.8)	

Generator Specifications

Standards

MJB Industrial generators meet the requirements of IEC 60034-1, CEI 2-3, BS 4999-5000, VDE 0530, NF 51-100,111 OVE M-10, and NEMA MG 1.22.

Excitation Systems

The generators are self-excited, by means of a brushless type excitation system. The voltage is maintained within $\pm 0,5\%$ of the nominal value in steady state condition with balanced and non distorting load.

The excitation system is fed by an auxiliary winding which gives a better response to the variation in loads and sustains the power supply in the case of a short-circuit.

The MJB Generators can be supplied with a Permanent Magnet Generator (PMG) on request, which gives an independent supply to the excitation system. PMG is advisable for use with generators such as unbalanced loads and distorting loads.

The MJB Generators are supplied with adjustable over-excitation protection which, when combined with an external protection system, will protect the alternator in the event of over-excitation.

Insulation

The insulation system is Class H. The Generators are impregnated with high grade resin, using the most modern technologies (VPI). A further protective treatment is applied on the whole range, making the generators suitable for the toughest environment conditions. Tropicalisation as standard on all generator series.

Shaft

The rotors are dynamically balanced with a half key applied to the shaft extension in accordance with IEC 60034-14 to vibration grade normal (N) in standard execution. Generators can be supplied with reduced (R) or special (S) vibration levels on request.

Windings & Electrical Performance

MJB Generators for Industrial application are supplied with 2/3 pitch winding to reduce the voltage harmonic content in applications with non-linear loads. The no-load waveform is sinusoidal with a residual harmonic $\leq 2\%$ Total Harmonic Distortion (THD) $\leq 2\%$.

Telephone Interference

The Telephonic Harmonic Factor (THF) is less than 2 % as defined by IEC 60034-1.

Radio Interference

Radio Interference conforms to Class B Group 1 as defined by EN55011.

Enclosure

The standard protection is IP23. The MJB can be supplied with protection degree IP43 on request. Higher protection degrees are available for larger frame sizes through the application of air-to-air or air-to-water heat exchangers.

Quality Assurance

Generators are manufactured using production procedures having a quality assurance level to BS EN (ISO9001).

Standard Features and Accessories

Standard Features

- * Heavy Duty Steel Base
- * Vibration Isolators
- * Battery Rack
- * Battery Cables
- * Owners Manual
- * Oil Drain Valve with Extensions
- * Flex Exhaust Connector
- * Radiator Overflow Bottle

Accessories

- Water Jacket Heater
- Exhaust Silencer
- Silencer Mounting Kit for Enclosure
- Weather Enclosure
- Sound Attenuated Enclosure
- Sub-base Fuel Tank
- Flexible Fuel Tank
- Battery
- Battery Heater
- Battery Charger
- Electronic Isochronous Governor
- PMG Exciter

Accessories

- Generator Strip Heater
- Line Circuit Breaker
- Lynx 100 Controls
- Lynx 200 Controls
- Lynx 300 Controls
- Alarm Horn
- Dry Contact Kit
- Remote Annunciator
- Interactive Telecommunications

Distributed By:



1270 Shiloh Road
Suite 100
Kennesaw, GA 30144
Phone: (770) 499-0439
Toll Free: 1-800-814-6502
Fax: (770) 499-8601