

# Lynx Power Systems

**Model: 200SG**

**Ratings:**

		50Hz	60Hz
<b>Standby:</b>	kw	200	200
	kva	250	281
<b>Prime:</b>	kw	175	200
	kva	219	250

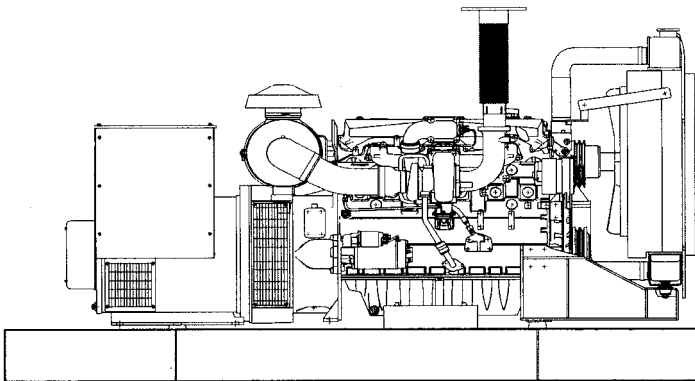

## Product Features

- \* System reliability and longevity begin with design experience and integrity.
- \* Heavy duty 4 cycle industrial engine for reliability and fuel efficiency.
- \* Heavy duty steel base with integral vibration isolators
- \* Single source responsibility for the generator set and accessories.
- \* Microprocessor based control system providing digital metering and monitoring.
- \* Brushless rotating field generator with class H insulation.
- \* Unit conforms to CSA, NEMA, EGSA, ANSI and other standards.
- \* Prototype and production tested to insure one step load acceptance per NFPA 110.
- \* Two year limited warranty on generator sets and accessories.
- \* Extended warranty available upon request.

# Application & Engineering Data

## POWER RATING

Condition	60Hz (1800rpm)	50Hz (1500rpm)
Prime	272PS (200kW)	238PS (175kW)
Standby	306PS (225kW)	272PS (200kW)

## MECHANICAL SYSTEM

Manufacture	Daewoo Heavy Industries and Machinery	
Engine model	GE12TIR	
Type	In-line 4 cycle, water cooled, Turbocharged, Intercooler air to air	
Combustion type	Premixed and spark ignited	
Cylinder	Type	Replaceable dry liner
	Number	6
	Bore x Stroke	123(4.84) x 155(6.1) mm(in.)
Displacement	11.051(674.5) lit.(in <sup>3</sup> )	
Compression ratio	10.5 : 1	
Firing order	1-5-3-6-2-4	
Ignition timing	25	
Compression pres.	Above 16 kg/cm <sup>2</sup> (228psi) at 200rpm	
Dry weight	Approximately 910kg (2,006lb)	
Dimension (LxWxH)	3100x1200x630mm (44x122x64in)	
Rotation	Counter Clockwise viewed from flywheel	

## COOLING SYSTEM

Cooling method	Fresh water forced circulation
Water capacity(engine)	19 liters(5.02 gal.)
Pressure system	Max. 0.9 kg/cm <sup>2</sup> (12.8psi)
Water Pump	Centrifugal type driven by gear
Capacity	320 liters (84.5gal)/min at 1800rpm
Thermostat	Wax pellet type
	Opening temp. 83°C
	Full open temp. 95°C
Cooling fan	Blower, 755mm diameter, 7 blades Plastic

## MECHANISM

Type	Overhead valve
Number of valves	Intake 1, exhaust 1 per cylinder
Valve lashes	Intake 0.30mm (0.012in.) cold
	Exhaust 0.30mm (0.012 in.) cold
Valve timing	Opening Close
	Intake valve 18° BTDC, 34° ABDC
Exhaust valve	46° BBDC, 14° ATDC

## FUEL SYSTEM

Carburetor	Impco carburetor
Gas regulator	Maxitrol RV 81
Max. inlet pressure	1.0 psi at the engine inlet
Shut-off valve	24VDC type solenoid valve
Used fuel	Natural gas (min LHV 900Btu/ft <sup>3</sup> )
Governor	Electronic/Isochronous

## FUEL CONSUMPTION

SCF / min	
Theoretical @ max Output	38.5 ft <sup>3</sup> /min @ 225 kW

## ENGINEERING DATA

Water flow	@1500 rpm 250 liters/min @1800 rpm 280 liters/min
Heat rejection to coolant	@1800 rpm 36 Kcal/sec
Heat rejection to CAC	@1800 rpm 8 Kcal/sec
Air flow	@ 1500 rpm 10.2 m <sup>3</sup> /min @ 1800 rpm 13.2 m <sup>3</sup> /min
Exhaust gas flow	@1800 rpm 33 m <sup>3</sup> /min
Exhaust gas temp.	@ 1800 rpm 460°C
Max permissible restrictions	
Intake system	203 mm H2O initial 381 mm H2O final
Exhaust system	600 mm H2O
Altitude Capability	1500 m

## LUBRICATION SYSTEM

Lub. Method	Full forced pressure feed type
Oil pump	Gear type driven by crankshaft
Oil filter	Full flow, cartridge type
Oil pan capacity	High level 23 liters (6.1 gal)
	Low level 20 liters (5.3 gal)
Angularity limit	Front down 25°
	Front up 25°
	Side to side 15°
Lub. Oil	Low ash type (0.5 wt%) natural gas engine oil API service grade CD or higher SAE 15w-40

## ELECTRICAL SYSTEM

Charging generator	24V x 45A alternator
Voltage regulator	Built-in type IC regulator
Starting motor	24V x 6.0kw
Battery voltage	24V
Capacity (recommended)	120 AH
Ignition controller	12 or 24VDC (min 8 VDC at start, 32 VDC max)
Shut-off valve	24VDC

## IGNITION SYSTEM

Spark plug	Champion RC78PYP, 0.38mm air gap
Ignition controller	Inductive-I unit (12 or 24 VDC) with adjustable dwell and programmable timing modes
Ignition coil	Individual coil
Trigger system	Magnetic pick-up system and trigger wheel (0.75+ /- 0.25 air gap)

## CONVERSION TABLE

PS=kW x 1.3596	kg/hr=M <sup>3</sup> /hr x 0.732 (natural gas)
M <sup>3</sup> =SCF x 0.0283	Btu/ft <sup>3</sup> =Mj/m <sup>3</sup> x 26.8392 (natural gas)

## FLYWHEEL & HOUSING

SAE # 1

# **Control Panel**

---

Standard Control Panel provides: Digital readout of AC volts, AC amps and frequency; continuous display of engines. Oil pressure, water temperature and battery voltage; display of running time, system diagnostics and service information, safety shutdowns for overcrank, overspeed, low oil pressure and high water temperature; and remote and local start/stop capabilities with speed signal monitoring.

## **Generator Specifications**

---

### **Standards**

MJB Industrial generators meet the requirements of IEC 60034-1, CEI 2-3, BS 4999-5000, VDE 0530, NF 51-100,111 OVE M-10, and NEMA MG 1.22.

### **Excitation Systems**

The generators are self-excited, by means of a brushless type excitation system. The voltage is maintained within  $\pm 0,5\%$  of the nominal value in steady state condition with balanced and non distorting load.

The excitation system is fed by an auxiliary winding which gives a better response to the variation in loads and sustains the power supply in the case of a short-circuit.

The MJB Generators can be supplied with a Permanent Magnet Generator (PMG) on request, which gives an independent supply to the excitation system. PMG is advisable for use with generators such as unbalanced loads and distorting loads.

The MJB Generators are supplied with adjustable over-excitation protection which, when combined with an external protection system, will protect the alternator in the event of over-excitation.

### **Insulation**

The insulation system is Class H. The Generators are impregnated with high grade resin, using the most modern technologies (VPI). A further protective treatment is applied on the whole range, making the generators suitable for the toughest environment conditions. Tropicalisation as standard on all generator series.

### **Shaft**

The rotors are dynamically balanced with a half key applied to the shaft extension in accordance with IEC 60034-14 to vibration grade normal (N) in standard execution. Generators can be supplied with reduced (R) or special (S) vibration levels on request.

### **Windings & Electrical Performance**

MJB Generators for Industrial application are supplied with 2/3 pitch winding to reduce the voltage harmonic content in applications with non-linear loads. The no-load waveform is sinusoidal with a residual harmonic  $\leq 2\%$  Total Harmonic Distortion (THD)  $\leq 2\%$ .

### **Telephone Interference**

The Telephonic Harmonic Factor (THF) is less than 2 % as defined by IEC 60034-1.

### **Radio Interference**

Radio Interference conforms to Class B Group 1 as defined by EN55011.

### **Enclosure**

The standard protection is IP23. The MJB can be supplied with protection degree IP43 on request. Higher protection degrees are available for larger frame sizes through the application of air-to-air or air-to-water heat exchangers.

### **Quality Assurance**

Generators are manufactured using production procedures having a quality assurance level to BS EN (ISO9001).

# Standard Features and Accessories

---

## Standard Features

- \* Heavy Duty Steel Base
- \* Vibration Isolators
- \* Battery Rack
- \* Battery Cables
- \* Owners Manual
- \* Oil Drain Valve with Extensions
- \* Flex Exhaust Connector
- \* Radiator Overflow Bottle

## Accessories

- Water Jacket Heater
- Exhaust Silencer
- Silencer Mounting Kit for Enclosure
- Weather Enclosure
- Sound Attenuated Enclosure
- Sub-base Fuel Tank
- Flexible Fuel Tank
- Battery
- Battery Heater
- Battery Charger
- Electronic Isochronous Governor
- PMG Exciter

## Accessories

- Generator Strip Heater
- Line Circuit Breaker
- Lynx 100 Controls
- Lynx 200 Controls
- Lynx 300 Controls
- Alarm Horn
- Dry Contact Kit
- Remote Annunciator
- Interactive Telecommunications

**Distributed By:**



1270 Shiloh Road  
Suite 100  
Kennesaw, GA 30144  
Phone: (770) 499-0439  
Toll Free: 1-800-814-6502  
Fax: (770) 499-8601