

Lynx Power Systems

Model: 300SG

Ratings:

		50Hz	60Hz
Standby:	kw	264	300
	kva	330	375
Prime:	kw	230	270
	kva	288	338

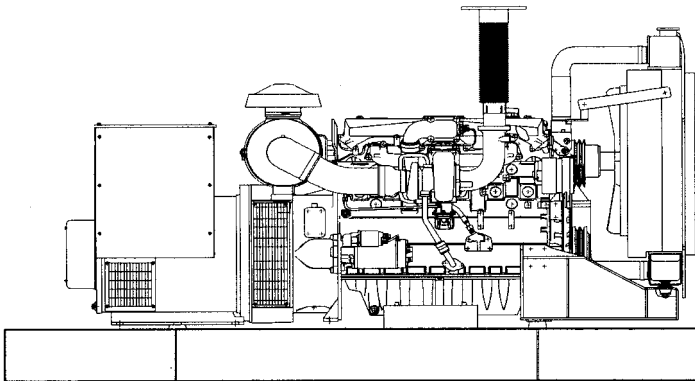

Product Features

- * System reliability and longevity begin with design experience and integrity.
- * Heavy duty 4 cycle industrial engine for reliability and fuel efficiency.
- * Heavy duty steel base with integral vibration isolators
- * Single source responsibility for the generator set and accessories.
- * Microprocessor based control system providing digital metering and monitoring.
- * Brushless rotating field generator with class H insulation.
- * Unit conforms to CSA, NEMA, EGSA, ANSI and other standards.
- * Prototype and production tested to insure one step load acceptance per NFPA 110.
- * Two year limited warranty on generator sets and accessories.
- * Extended warranty available upon request.

Application & Engineering Data

POWER RATING

Condition	60Hz (1800rpm)	50Hz (1500rpm)
Prime	367PS (270kW)	313PS (230kW)
Standby	408PS (300kW)	359PS (264kW)

MECHANICAL SYSTEM

Manufacture	Daewoo Heavy Industries and Machinery	
Engine model	GV158TIR	
Type	V-Type 4 cycle, water cooled, T/I (water to air)	
Combustion type	Premixed and spark ignited	
Cylinder	Type	Replaceable wet liner
	Number	8
	Bore x Stroke	128(5.04) x 142(5.59) mm(in.)
Displacement	14.618(892.05) lit.(in. ³)	
Compression ratio	10.5 : 1	
Firing order	1-5-7-2-6-3-4-8-1	
Ignition timing	14	
Compression pres.	Above 28 kg/cm ² (398psi) at 200rpm	
Dry weight	Approximately 950kg	
Dimension (LxWxH)	1484x1389x1145mm (58x55x45 in)	
Rotation	Counter Clockwise viewed from flywheel	

COOLING SYSTEM

Cooling method	Fresh water forced circulation
Water capacity(engine)	20 liters(5.28 gal.)
Pressure system	Max. 0.9 kg/cm ² (12.8psi)
Water Pump	Centrifugal type driven by gear
Capacity	410 liters (108gal)/min at 1800rpm (engine)
Thermostat	Wax pellet type
	Opening temp. 83°C
	Full open temp. 95°C
Cooling fan	Blower, 915mm diameter, 7 blades
	Plastic

MECHANISM

Type	Overhead valve	
Number of valves	Intake 1, exhaust 1 per cylinder	
Valve lashes	Intake	0.30mm (0.0118 in.)
	Exhaust	0.305mm (0.0118 in.) at cold
Valve timing	Opening	Close
Intake valve	18° BTDC, 34° ABDC	
Exhaust valve	46° BBDC, 14° ATDC	

FUEL SYSTEM

Carburetor	Impco Varifuel carburetor
Gas regulator	Impco
Max. inlet pressure	1.0 psi at the engine inlet
Shut-off valve	24VDC type solenoid valve
Used fuel	Natural gas (min LHV 900Btu/ft ³)
Governor	Electronic/Isochronous

FUEL CONSUMPTION

Consumption @ max Output: 49.8 CFM @ 300kW

ENGINEERING DATA

Water flow	@1500 rpm 340 liters/min
	@1800 rpm 410 liters/min
Heat rejection to coolant	@1800 rpm : 65 Kcal/sec
Heat rejection to CAC	@1800 rpm : 4.5 Kcal/sec
Air flow	@ 1500 rpm 11.6 m ³ /min
	@ 1800 rpm 15.1 m ³ /min
Exhaust gas flow	@1800 rpm 58 m ³ /min
Exhaust gas temp.	@ 1800 rpm 480°C
Max permissible restrictions	
Intake system	220 mm H2O initial
	635 mm H2O final
Exhaust system	600 mm H2O
Altitude Capability	1500 m

LUBRICATION SYSTEM

Lub. Method	Full forced pressure feed type
Oil pump	Gear type driven by crankshaft
Oil filter	Full flow, cartridge type
Oil pan capacity	High level 28 liters (7.4 gal)
	Low level 26 liters (6.9 gal)
Angularity limit	Front down 35°
	Front up 35°
	Side to side 35°
Lub. Oil	Low ash type (0.5 wt%) natural gas engine oil API service grade CD or higher SAE 15w-40

ELECTRICAL SYSTEM

Charging generator	24V x 45A alternator
Voltage regulator	Built-in type IC regulator
Starting motor	24V x 6.0kw
Battery voltage	24V
Capacity (recommended)	200 AH
Ignition controller	12 or 24VDC (min 8 VDC at start, 32 VDC max)
Shut-off valve	24VDC

IGNITION SYSTEM

Spark plug	Champion RC78PYP, 0.38mm air gap
Ignition controller	Induction type non-waste system with two programable timing modes
Trigger system	Magnetic pick-up system and trigger wheel and Hall-effect (0.5 / 0.5 / 1.0 mm air gap)

CONVERSION TABLE

PS=kW x 1.3596	kg/hr=Nm ³ /hr x 0.732 (natural gas)
Nm ³ =SCF x 0.0283	Btu/ft=Mj/m ³ x 26.8392 (natural gas)

Control Panel

Standard Control Panel provides: Digital readout of AC volts, AC amps and frequency; continuous display of engines. Oil pressure, water temperature and battery voltage; display of running time, system diagnostics and service information, safety shutdowns for overcrank, overspeed, low oil pressure and high water temperature; and remote and local start/stop capabilities with speed signal monitoring.

Generator Specifications

Standards

MJB Industrial generators meet the requirements of IEC 60034-1, CEI 2-3, BS 4999-5000, VDE 0530, NF 51-100,111 OVE M-10, and NEMA MG 1.22.

Excitation Systems

The generators are self-excited, by means of a brushless type excitation system. The voltage is maintained within $\pm 0,5\%$ of the nominal value in steady state condition with balanced and non distorting load.

The excitation system is fed by an auxiliary winding which gives a better response to the variation in loads and sustains the power supply in the case of a short-circuit.

The MJB Generators can be supplied with a Permanent Magnet Generator (PMG) on request, which gives an independent supply to the excitation system. PMG is advisable for use with generators such as unbalanced loads and distorting loads.

The MJB Generators are supplied with adjustable over-excitation protection which, when combined with an external protection system, will protect the alternator in the event of over-excitation.

Insulation

The insulation system is Class H. The Generators are impregnated with high grade resin, using the most modern technologies (VPI). A further protective treatment is applied on the whole range, making the generators suitable for the toughest environment conditions. Tropicalisation as standard on all generator series.

Shaft

The rotors are dynamically balanced with a half key applied to the shaft extension in accordance with IEC 60034-14 to vibration grade normal (N) in standard execution. Generators can be supplied with reduced (R) or special (S) vibration levels on request.

Windings & Electrical Performance

MJB Generators for Industrial application are supplied with 2/3 pitch winding to reduce the voltage harmonic content in applications with non-linear loads. The no-load waveform is sinusoidal with a residual harmonic $\leq 2\%$ Total Harmonic Distortion (THD) $\leq 2\%$.

Telephone Interference

The Telephonic Harmonic Factor (THF) is less than 2 % as defined by IEC 60034-1.

Radio Interference

Radio Interference conforms to Class B Group 1 as defined by EN55011.

Enclosure

The standard protection is IP23. The MJB can be supplied with protection degree IP43 on request. Higher protection degrees are available for larger frame sizes through the application of air-to-air or air-to-water heat exchangers.

Quality Assurance

Generators are manufactured using production procedures having a quality assurance level to BS EN (ISO9001).

Standard Features and Accessories

Standard Features

- * Heavy Duty Steel Base
- * Vibration Isolators
- * Battery Rack
- * Battery Cables
- * Owners Manual
- * Oil Drain Valve with Extensions
- * Flex Exhaust Connector
- * Radiator Overflow Bottle

Accessories

- Water Jacket Heater
- Exhaust Silencer
- Silencer Mounting Kit for Enclosure
- Weather Enclosure
- Sound Attenuated Enclosure
- Sub-base Fuel Tank
- Flexible Fuel Tank
- Battery
- Battery Heater
- Battery Charger
- Electronic Isochronous Governor
- PMG Exciter

Accessories

- Generator Strip Heater
- Line Circuit Breaker
- Lynx 100 Controls
- Lynx 200 Controls
- Lynx 300 Controls
- Alarm Horn
- Dry Contact Kit
- Remote Annunciator
- Interactive Telecommunications

Distributed By:



1270 Shiloh Road
Suite 100
Kennesaw, GA 30144
Phone: (770) 499-0439
Toll Free: 1-800-814-6502
Fax: (770) 499-8601