

# Lynx Power Systems

**Model: 40SG**

**Ratings:**

		50Hz	60Hz
<b>Standby:</b>	kw	31	40
	kva	39	50
<b>Prime:</b>	kw	24	33
	kva	31	41

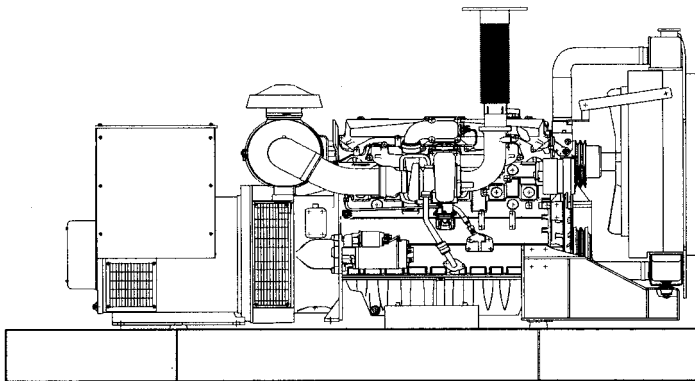

## Product Features

- \* System reliability and longevity begin with design experience and integrity.
- \* Heavy duty 4 cycle industrial engine for reliability and fuel efficiency.
- \* Heavy duty steel base with integral vibration isolators.
- \* Single source responsibility for the generator set and accessories.
- \* Microprocessor based control system providing digital metering and monitoring.
- \* Brushless rotating field generator with class H insulation.
- \* Unit conforms to CSA, NEMA, EGSA, ANSI and other standards.
- \* Prototype and production tested to insure one step load acceptance per NFPA 110.
- \* Two year limited warranty on generator sets and accessories.
- \* Extended warranty available upon request.

# Application & Engineering Data

## Engine Specifications

Make	GM
Model	4.3
Cylinders	V-6
Displacement	4.3 Liter (264 cu. In.)
Bore	101.6 mm (4.0 in.)
Stroke	88 mm (3.48 in.)
Compression Ratio	9.05:1
Intake Air	Naturally Aspirated
Number of Main Bearings	4
Connecting Rods	6-Drop Forged Steel
Cylinder Head	Cast Iron
Pistons	6-Notched Head, Aluminum Alloy
Crankshaft	Nodular Steel

## Cooling System

Type of System	Pressurized, Closed Recovery
Water Pump	Pre-Lubed, Self-Self Healing
Type of Fan	Pusher
Number of Fan Blades	7
Diameter of Fan	431 mm (17 in.)
Coolant Heater	120V, 1800W

## Electrical System

Battery Charge Alternator	100 Amps at 12V
Starter Motor	12V
Recommended Battery	(1) - 12V, 90 A.H., 27F
Ground Polarity	Negative

## Standby

### Generator Output KW (60Hz)

<u>N.G.</u>	<u>L.P.</u>
40KW	40KW

### Generator Output KW (50Hz)

<u>N.G.</u>	<u>L.P.</u>
31KW	31KW

## Fuel

Fuel Consumption-60Hz-100% Load	<u>N.G.</u>	<u>L.P.</u>
ft. <sup>3</sup> (gal.) / hr.	763	303
m <sup>3</sup> (lit.) /hr.	21.6	8.57
Fuel Consumption-50Hz-100% Load	<u>N.G.</u>	<u>L.P.</u>
ft. <sup>3</sup> (gal.) / hr.	619	246
m <sup>3</sup> (lit.) /hr.	17.5	6.96

## Cooling

Coolant Capacity	System	19 lit. (5 US gal.)	19 lit. (5 US gal.)
	Engine	8 lit. (2 US gal.)	8 lit. (2 US gal.)
	Radiator	11 lit. (3 US gal.)	11 lit. (3 US gal.)
Coolant Flow/Min.	60 Hz	90 lit. (24 US gal.)	90 lit. (24 US gal.)
	50 Hz	75 lit. (20 US gal.)	75 lit. (20 US gal.)
Heat Rejection to Coolant		235,000 BTU / hr.	200,000 BTU / hr.
	Inlet Air	60 Hz 212 m <sup>3</sup> /min <sup>3</sup> (7500 cfm)	212 m <sup>3</sup> /min. (7500 cfm)
	50 Hz	177 m <sup>3</sup> / min. <sup>3</sup> (6250 cfm)	177 m <sup>3</sup> / min. (6250 cfm)
Max. Inlet Air Temperature		110°F	110°F

## Combination Air Requirements

Flow at Rated Power	60 Hz	4.53 m <sup>3</sup> /min. <sup>3</sup> (160 cfm)	4.53 m <sup>3</sup> /min. (160 cfm)
	50 Hz	3.82 m <sup>3</sup> / min. <sup>3</sup> (135 cfm)	3.82 m <sup>3</sup> / min. (135 cfm)

## Exhaust

Exhaust Flow at Rated Output	60 Hz	18.1 m <sup>3</sup> /min. <sup>3</sup> (640 cfm)	11.32 m <sup>3</sup> /min. (400 cfm)
	50 Hz	15 m <sup>3</sup> / min. <sup>3</sup> (530 cfm)	9.42 m <sup>3</sup> / min. (333 cfm)
Maximum Recommended Back Pressure		5.0 Kpa (1.5" Hg)	5.0 Kpa (1.5" Hg)
Exhaust Temperature at Rated Output		650°C (1200°F)	593°C (1100°F)
Exhaust Outlet Size		2.5"	2.5"

## Engine

Rated RPM	60 Hz	1800	1800
	50 Hz	1500	1500
HP at Rated KW	60 Hz	80	64
	50 Hz	64	51
Piston Speed	60 Hz	317 m/min. (1040 ft./min.)	317 m/min. (1040 ft./min.)
	50 Hz	264 m/min. (866 ft./min.)	264 m/min. (866 ft./min.)
BMEP	60 Hz	101	80
	50 Hz	97	77

## Deration Factors

Temperature	5% for every 10°C	43°C	43°C
	2.77% for Every 10 F Above	110°F	110°F
Altitude	1.1% for Every 100 m Above	150 m	150 m
	3.5% for Every 1000 Ft. Above	500 ft.	500 ft.

## Fuel System

Fuel	Standard
Natural Gas or L.P. vapor	Optional
L.P. Liquid Withdrawal	
Carburetor	Downdrafts
Secondary Fuel Regulator	Nat. Gas or L.P. Vapor System
Hot Water Vaporizer	L.P. Liquid Withdrawal Systems
Automatic Fuel Lockoff Solenoid	Standard
Operating Fuel Pressure Vapor Systems	7" to 15" H <sub>2</sub> O

## Lubrication System

Type of Oil Pump	Trochoid
Oil Filter	Full Flow, Cartridge
Crank Capacity	3.8 Liters (4 qts.)

## Valve Train

Lifter Type	Hydraulic
Intake Valve Material	Aluminized Steel Faced
Exhaust Valve Material	Stellite Faced
Valve Seats	Standard

## Engine Governor

Electronic	Standard
Frequency Regulation, No Load to Full Load	0.50%
Steady State Regulation	± 0.25%

## Prime

40SG

<u>N.G.</u>	<u>L.P.</u>
33KW	33KW

<u>N.G.</u>	<u>L.P.</u>
24KW	24KW

<u>N.G.</u>	<u>L.P.</u>
17.1	6.76

<u>N.G.</u>	<u>L.P.</u>
603	239
17.1	6.76
<u>N.G.</u>	<u>L.P.</u>
490	195
13.9	5.52

# **Control Panel**

---

---

Standard Control Panel provides: Digital readout of AC volts, AC amps and frequency; continuous display of engines. Oil pressure, water temperature and battery voltage; display of running time, system diagnostics and service information, safety shutdowns for overcrank, overspeed, low oil pressure and high water temperature; and remote and local start/stop capabilities with speed signal monitoring.

## **Generator Specifications**

---

---

### **Standards**

MJB Industrial generators meet the requirements of IEC 60034-1, CEI 2-3, BS 4999-5000, VDE 0530, NF 51-100,111 OVE M-10, and NEMA MG 1.22.

### **Excitation Systems**

The generators are self-excited, by means of a brushless type excitation system. The voltage is maintained within  $\pm 0,5\%$  of the nominal value in steady state condition with balanced and non distorting load.

The excitation system is fed by an auxiliary winding which gives a better response to the variation in loads and sustains the power supply in the case of a short-circuit.

The MJB Generators can be supplied with a Permanent Magnet Generator (PMG) on request, which gives an independent supply to the excitation system. PMG is advisable for use with generators such as unbalanced loads and distorting loads.

The MJB Generators are supplied with adjustable over-excitation protection which, when combined with an external protection system, will protect the alternator in the event of over-excitation.

### **Insulation**

The insulation system is Class H. The Generators are impregnated with high grade resin, using the most modern technologies (VPI). A further protective treatment is applied on the whole range, making the generators suitable for the toughest environment conditions. Tropicalisation as standard on all generator series.

### **Shaft**

The rotors are dynamically balanced with a half key applied to the shaft extension in accordance with IEC 60034-14 to vibration grade normal (N) in standard execution. Generators can be supplied with reduced (R) or special (S) vibration levels on request.

### **Windings & Electrical Performance**

MJB Generators for Industrial application are supplied with 2/3 pitch winding to reduce the voltage harmonic content in applications with non-linear loads. The no-load waveform is sinusoidal with a residual harmonic  $\leq 2\%$  Total Harmonic Distortion (THD)  $\leq 2\%$ .

### **Telephone Interference**

The Telephonic Harmonic Factor (THF) is less than 2 % as defined by IEC 60034-1.

### **Radio Interference**

Radio Interference conforms to Class B Group 1 as defined by EN55011.

### **Enclosure**

The standard protection is IP23. The MJB can be supplied with protection degree IP43 on request. Higher protection degrees are available for larger frame sizes through the application of air-to-air or air-to-water heat exchangers.

### **Quality Assurance**

Generators are manufactured using production procedures having a quality assurance level to BS EN (ISO9001).

# Standard Features and Accessories

---

## Standard Features

- \* Heavy Duty Steel Base
- \* Vibration Isolators
- \* Battery Rack
- \* Battery Cables
- \* Owners Manual
- \* Oil Drain Valve with Extensions
- \* Flex Exhaust Connector
- \* Radiator Overflow Bottle

## Accessories

- Water Jacket Heater
- Exhaust Silencer
- Silencer Mounting Kit for Enclosure
- Weather Enclosure
- Sound Attenuated Enclosure
- Sub-base Fuel Tank
- Flexible Fuel Tank
- Battery
- Battery Heater
- Battery Charger
- Electronic Isochronous Governor
- PMG Exciter

## Accessories

- Generator Strip Heater
- Line Circuit Breaker
- Lynx 100 Controls
- Lynx 200 Controls
- Lynx 300 Controls
- Alarm Horn
- Dry Contact Kit
- Remote Annunciator
- Interactive Telecommunications

**Distributed By:**



1270 Shiloh Road  
Suite 100  
Kennesaw, GA 30144  
Phone: (770) 499-0439  
Toll Free: 1-800-814-6502  
Fax: (770) 499-8601